

6139A Automatic Chronograph

1 Specifications

Casing diameter	27.00 mm
Height	6.65 mm
Vibrations per hour	21,600
Automatic winding	
Calendar (Day & date, bilingual change-over mechanism for day indication, instant day & date setting device)	
Chronograph (1/5 second, one revolution in 60 seconds, 30 minutes totalizer, accumulated)	

2 Features

An advanced automatic winding chronograph

6139A Automatic Chronograph is a high-grade functional watch in which a chronograph mechanism and an automatic winding mechanism are compactly assembled. Addition of a calendar mechanism does not affect watch size and thickness.

Easy-to-use chronograph mechanism

The second hand and minute recorder can be activated by depressing the first button. Measured time can be accumulated just as with a regular chronograph.

Either one of two languages provided can be chosen to indicate the days of the week.

Numerous function and design features

In addition to 30- to 70-meter depth waterproofing (70-meter depth waterproof watch employs HARDLEX special reinforced glass), a variety of functions are provided such as tachymeter, pulsimeter, and rotating dial ring.

3 Disassembly and assembly

Disassemble the watch according to Figs.

①→⑦⑤

Assemble by reversing the above: Figs.

⑦⑤→①

Installation of the automatic winding mechanism varies compared with conventional watches.

The automatic winding mechanism should be installed after setting the movement with hands in the case.

4 Lubrication

Colored symbols in the illustrated figures indicate the types of oil, its quantities to be applied, and lubricating points.

▶ Moebius Synt-A-Lube

▶ Seiko watch oil S-4

Oil quantity

▶ Extremely small quantity

●▶ Normal quantity

●●▶ Sufficient quantity

✕ Oil must not be applied

Note: Unindicated portions do not require lubrication.

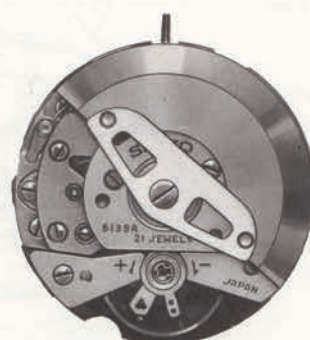

Movement

6139A Automatic Winding Mechanism

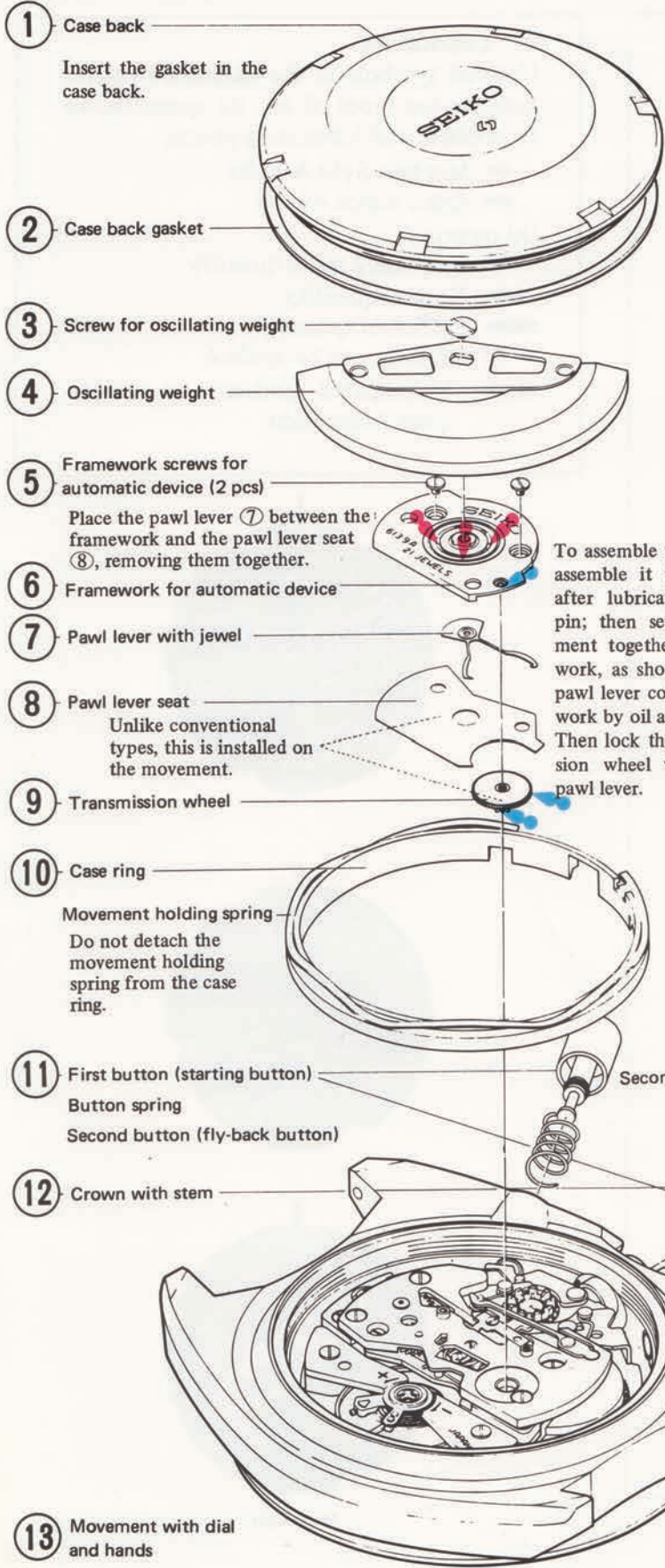

Structure of Button Portion

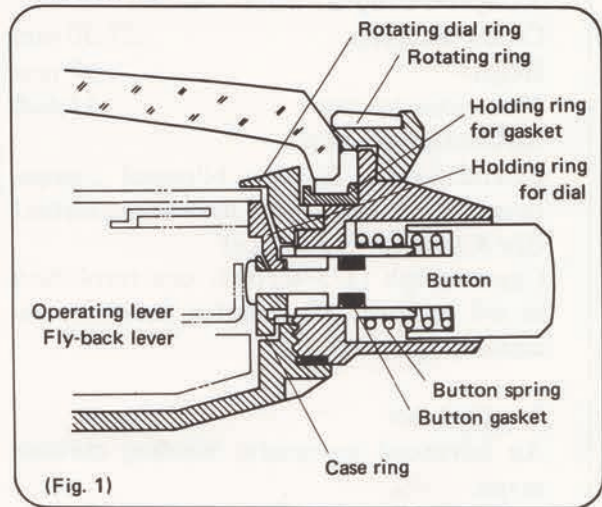

To assemble the pawl lever, first assemble it to the framework after lubricating the eccentric pin; then set it on the movement together with the framework, as shown in Fig. 2. (The pawl lever coheres to the framework by oil adhesion.) Then lock the teeth of transmission wheel with the teeth of pawl lever.

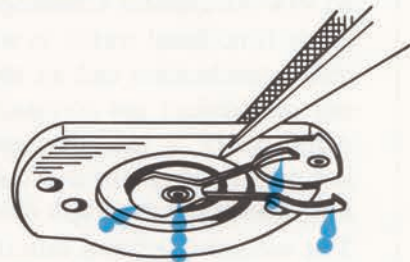

The two buttons **11** must be depressed simultaneously to either remove or insert the case ring.



6139A Calendar Mechanism

<Installing the second hand and chronograph minute hand>

- (1) At the fly-back position, tentatively set the hands on the "0" position.
- (2) Then repeat fly-back operation to foolproof the "0" position. If the hands fail to resume correct position, adjust the hands while depressing the fly-back button.
- (3) Completely push in hands at the point where they correctly indicate the "0" position.

NOTE:

The second hand axle is cut as shown in the diagram. If the second hand is turned by force after completely depressing it to the bottom, the hand will loosen.



SEIKO provides a handy Movement Holder S-500 exclusively for 6139A, to facilitate hand-setting.

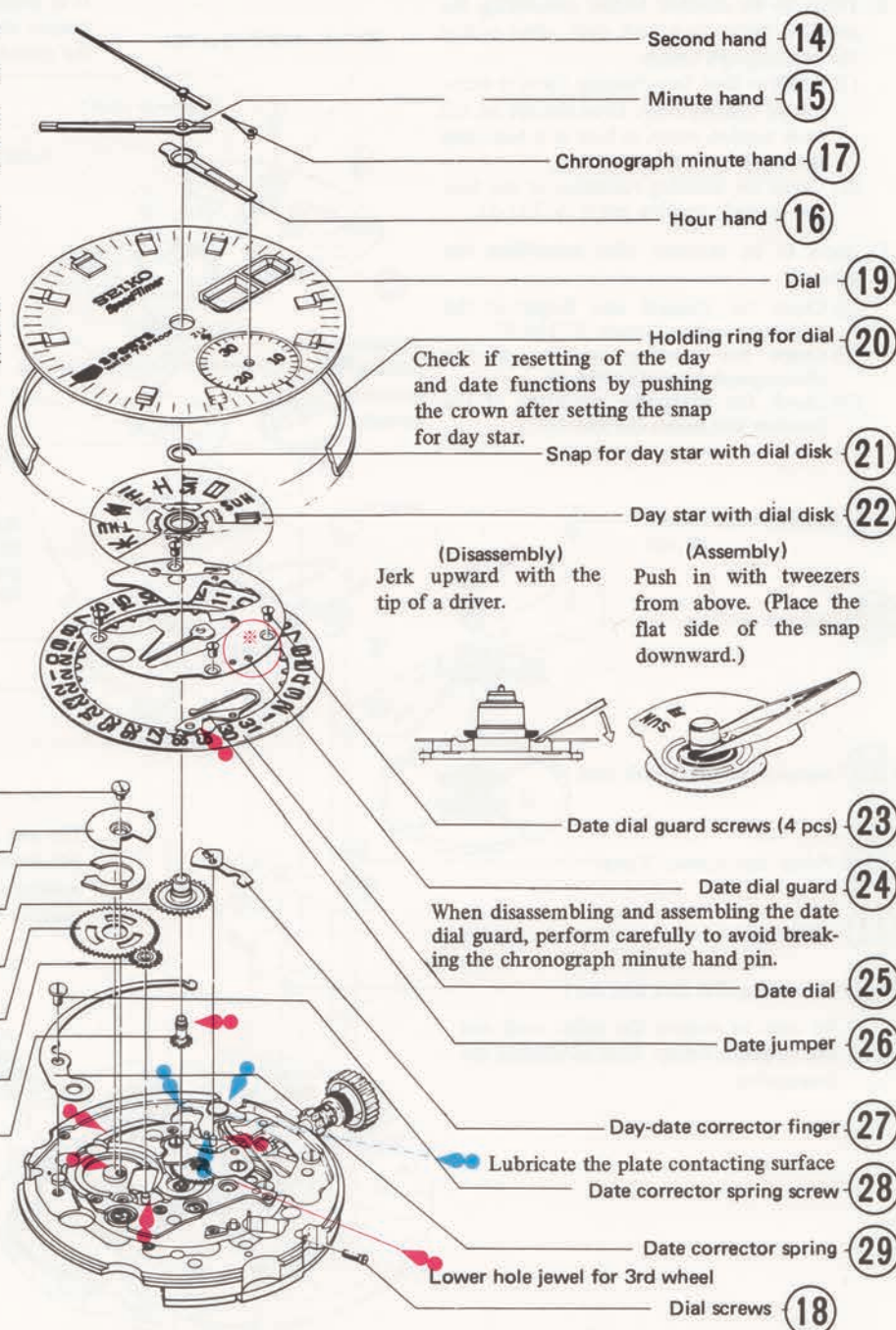
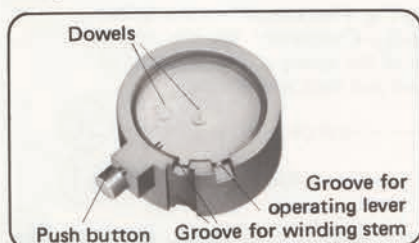

Calendar Mechanism

Day and date correction:

When fully depressing the crown from the ordinary position, the day and date are quickly forwarded by interlocking of stem, setting lever, date corrector, and day-date corrector finger.

Date correction:

When stopping the crown at an intermediate position, only the date changes.

Day correction:

Further depress the crown from the intermediate position to change only the week day indicated in English (or the other language being used). Once set, only the chosen language appears daily.

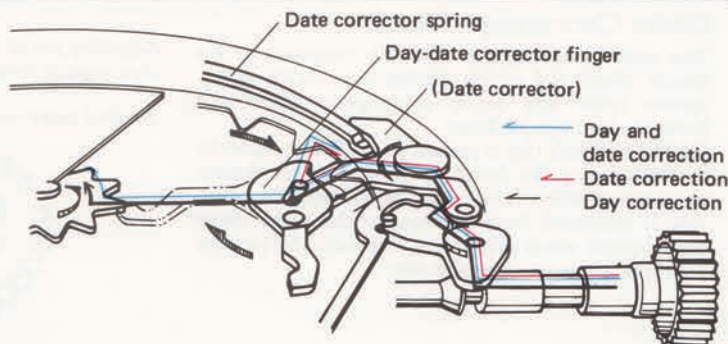

6139A Chronograph Mechanism,

1. Items to be checked before assembling the jewelled pallet fork and staff, after setting the chronograph bridge.

- (1) Confirm that free running force is transmitted unaffectedly. Even though no roll back motion exists, as long as it functions smoothly there is no problem.
- (2) Check for meshing condition of the first and second coupling levers (6139A-8).

2. Items to be checked after assembling the balance

- (1) Check for strength and Reight of the minute recording jumper (6139A-8).
- (2) Check for meshing position of the chronograph finger (6139A-9).
- (3) Check for contacting condition of the hammer and hearts (6139A-10).

37 - Balance cock screws (2 pcs)

38 - Balance cock

39 - Balance complete with stud

40 - Pallet cock screws (2 pcs)

41 - Pallet cock

42 - Jewelled pallet fork and staff

Be sure to remove the pallet cock and chronograph bridge after unwinding the mainspring.

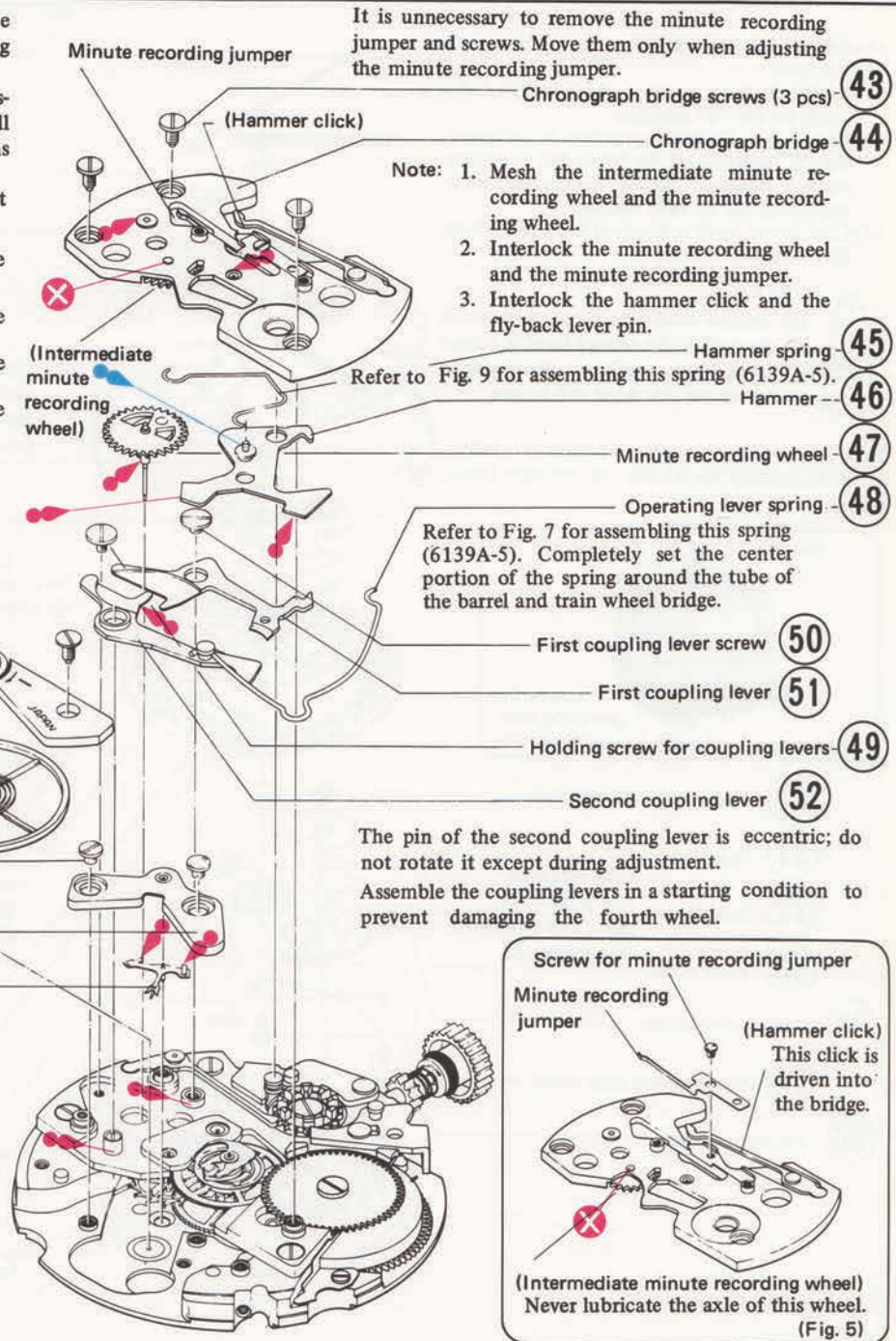

Center Chronograph Wheel

The center chronograph wheel is composed of the fourth wheel and pinion, clutch ring, clutch spring, second heart, and center chronograph wheel axle having a chronograph finger.

While the clutch ring is pressed to the fourth wheel by a clutch spring, the fourth wheel and center chronograph wheel axle revolve as one body. When the clutch ring is separated from the fourth wheel, the center chronograph wheel axle comes to a halt, and only the fourth wheel revolves individually.

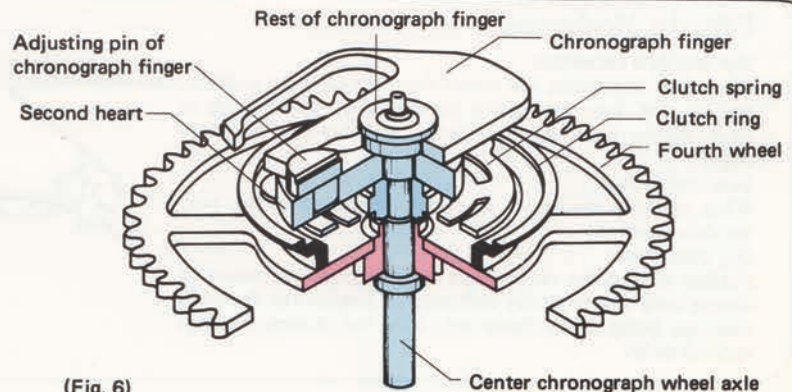

(Fig. 6)

6139A Operation of Chronograph Mechanism

Starting

When depressing the first button, the pillar wheel is forwarded one tooth and the pillar wheel contacting portion of the first coupling lever falls between the columns, and the first and second coupling levers are separated from the clutch ring. The clutch ring is pressed to the fourth wheel by the clutch spring, and the second hand starts moving.

When the second hand makes a complete turn, the chronograph finger forwards the minute recording wheel one tooth through the intermediate minute recording wheel, operating the minute hand one graduation.

Stopping

When depressing the first button in a started condition, the first and second coupling levers operate, raising the clutch ring. The clutch ring is separated from the fourth wheel, and the second hand comes to a halt. This time, the fourth wheel continues to rotate.

Accumulation

When further depressing the first button in a stopped condition, the mechanism returns to a starting condition (Fig. 7), and the chronograph hands restart from its stopped position, the measured time being accumulated.

Resetting

When depressing the second button in a stopped condition, the hammer is operated through the fly-back lever striking the second and minute hearts, and the hands are reset to the "0" position.

(When the hammer is on the column, i.e. the hands are in motion, the second button (fly-back button) cannot be depressed.)

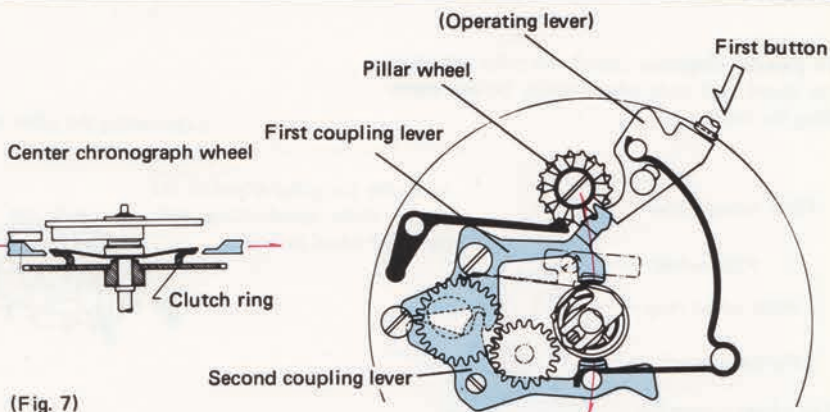

(Fig. 7)

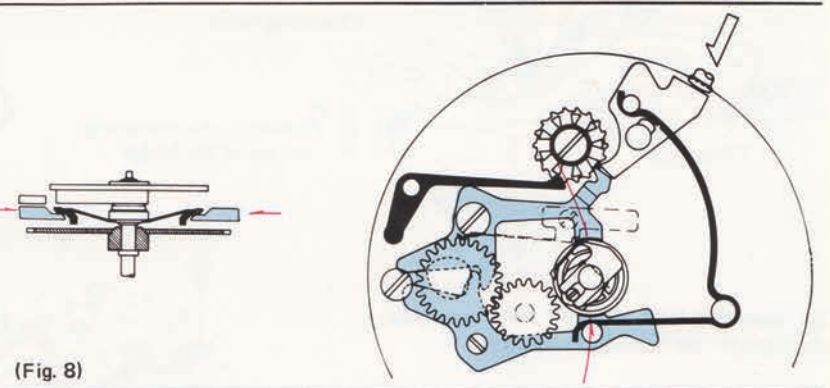

(Fig. 8)

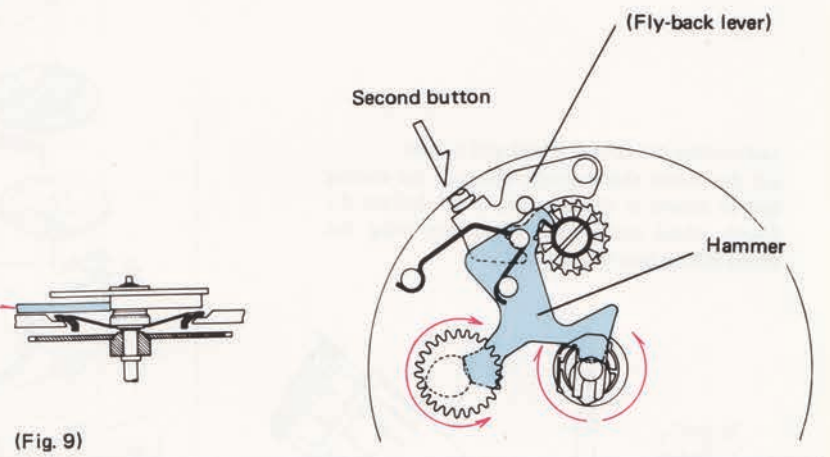

(Fig. 9)

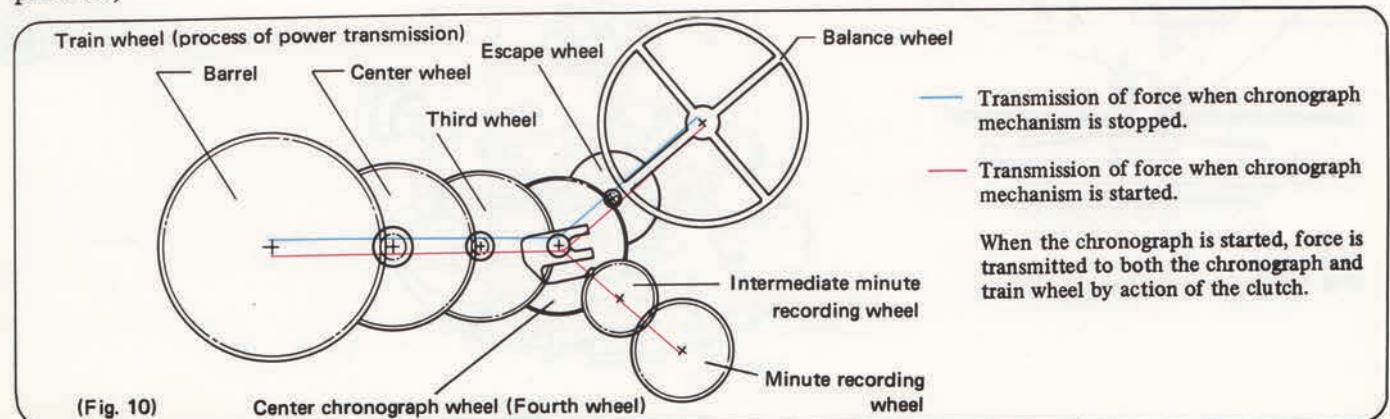

(Fig. 10)

6139A Train Wheel

To prevent chipping, install the pillar wheel on the barrel and train wheel bridge before assembling the latter.

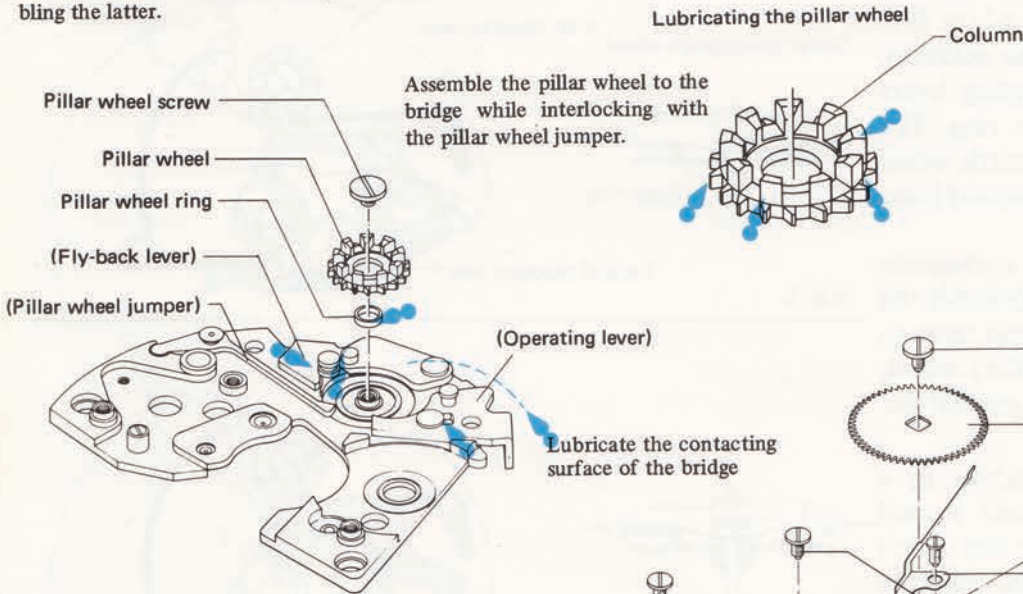

The operating lever, fly-back lever, and pillar wheel jumper are driven into the bridge.

Lubricating the fourth wheel and pinion:

Set the center chronograph wheel on the staking tool as shown in the diagram; then lubricate the fourth wheel and pinion while depressing the wheel with a pair of tweezers.

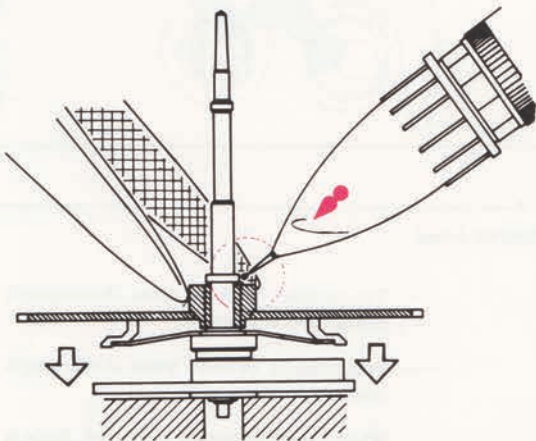

(Fig. 11)

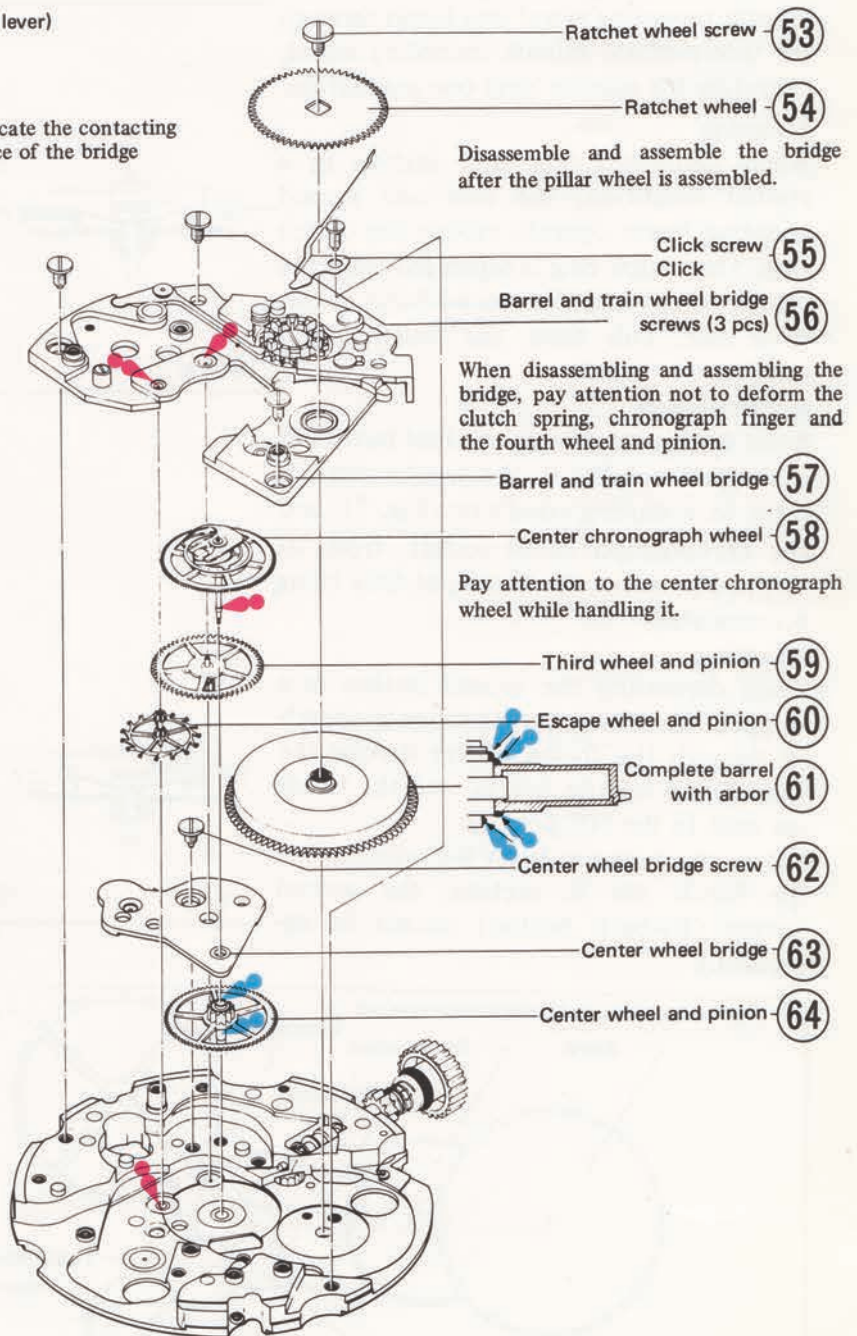

6139A Setting Mechanism

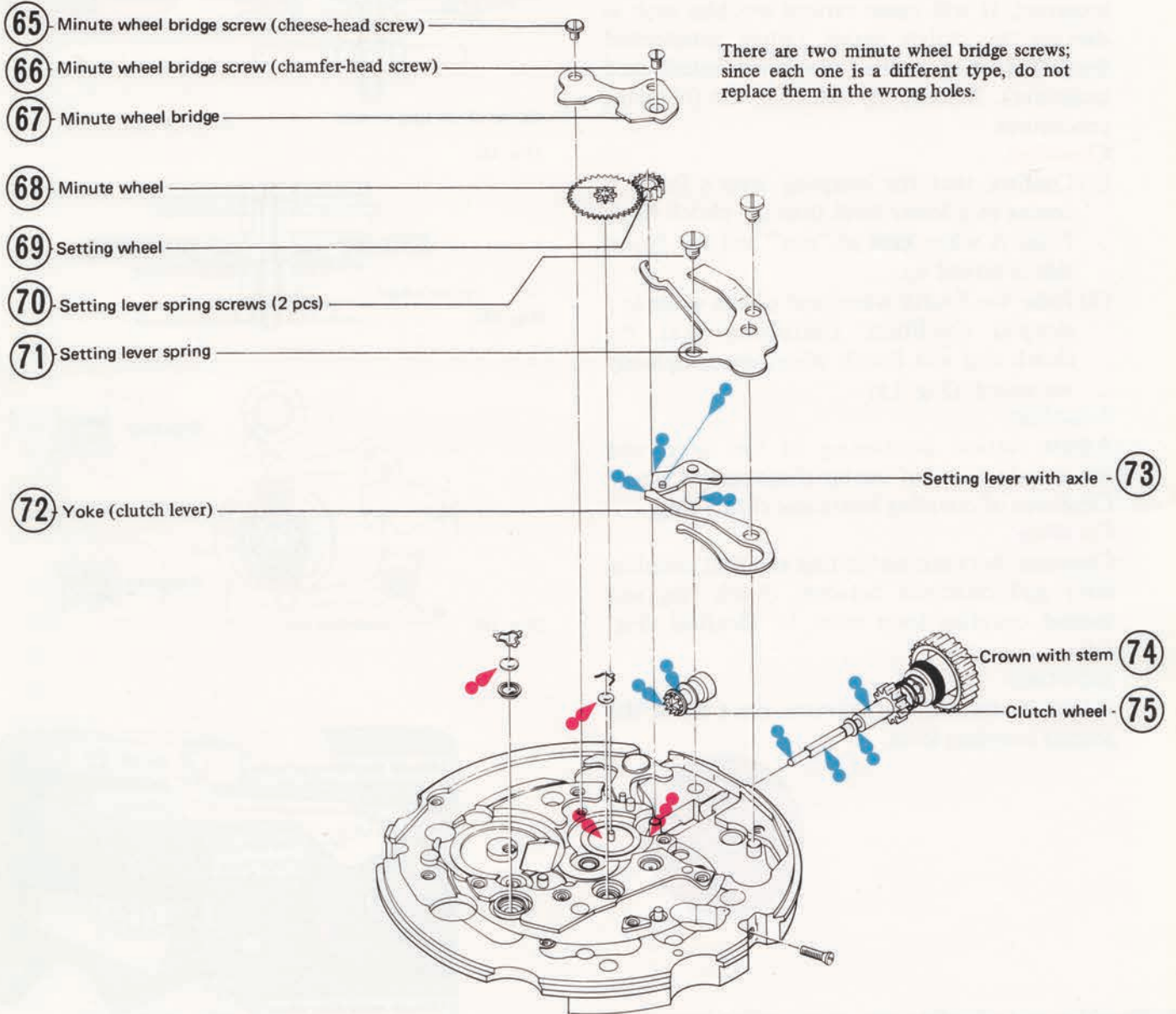

6139A Checking and Adjusting the Chronograph Mechanism-1

I. Checking and adjusting the coupling levers

- When the up and down interlocking condition between the coupling levers and clutch ring is incorrect, it will cause various troubles such as damage to clutch spring (when interlocked deeper), halting, or free run (when interlocked shallower). Remedy by effecting the following procedures.

Checking:

- Confirm that the coupling lever's Point B comes to a lower level than the clutch ring's Point A when kept at "run" and the bridge side is turned up.
- Raise the fourth wheel and pinion while in a stopped condition, confirming that the clutch ring and fourth wheel are completely separated. (Fig. 13)

Adjusting:

Adjust vertical positioning of the upper and lower hole jewel of center chronograph wheel.

- Clearance of coupling levers and clutch ring.

Checking:

Clearance between clutch ring and first coupling lever and clearance between clutch ring and second coupling lever must be identical (Fig. 14).

Adjusting:

Adjust by turning the eccentric pin (*) of the second coupling lever.

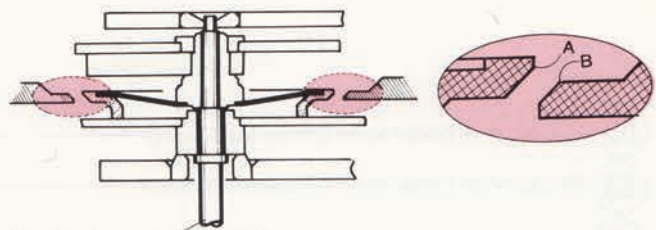
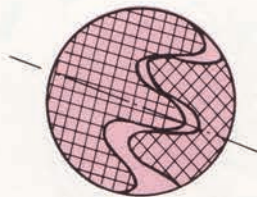

Center chronograph wheel

(Fig. 12)

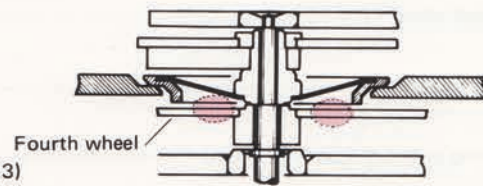

(Fig. 13)

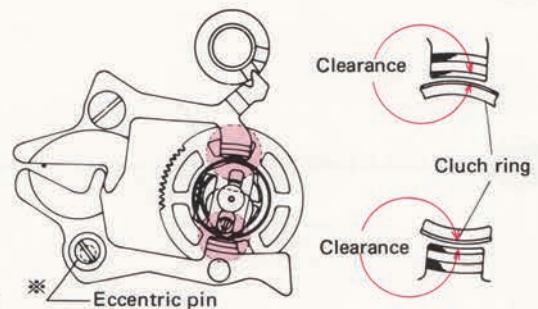

(Fig. 14)

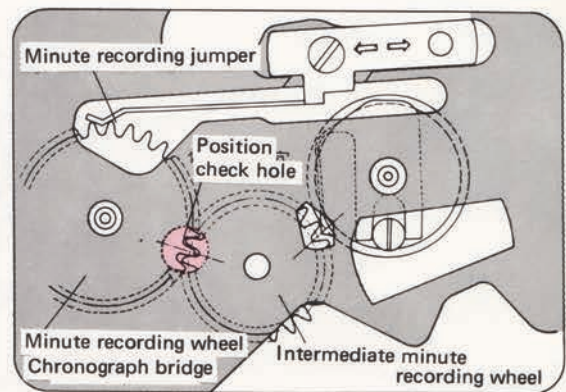

(Fig. 15)

II. Checking and adjusting minute recording jumper

- Correct positioning of minute recording jumper
Confirm that the three teeth of minute recording wheel can be observed symmetrically in the position check hole. (Fig. 15)

Adjusting:

Loosen the screw, and adjust the minute recording jumper by moving it to the right and left.

- Height of the minute recording jumper

Checking:

- Elevation of the minute recording jumper from the upper level of minute recording wheel must be less than half the thickness of the minute recording jumper. (Fig. 16)

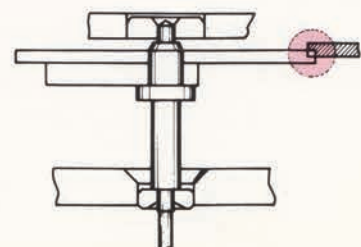

(Fig. 16)

6139A Checking and Adjusting the Chronograph Mechanism-2

- (2) By turning the minute recording wheel, confirm that the lower surface of the minute recording jumper does not contact top of the screw of first coupling lever. (Fig. 17)

Adjusting:

Bend the root of minute recording jumper either up or down. (Fig. 18)

3. Force of minute recording jumper

Insufficient force of minute recording jumper pressing against minute recording wheel results in retarding advance of the chronograph minute hand at forwarding time in minutes. If the force is too strong, it causes the chronograph minute hand to stop. Pay close attention to this.

Checking:

Check force of the minute recording jumper by strength of the mainspring.

- (1) After completely releasing the mainspring, start it by winding the ratchet wheel just halfway, confirming that the chronograph finger adequately activates the minute recording wheel.
- (2) Confirm that the minute recording jumper precisely regulates advance of the minute recording wheel. (Fig. 19)

Adjusting:

Bend the base of the minute recording jumper in either direction as indicated by arrows. (Fig. 20)

III. Adjusting the chronograph finger

1. Locking contact of chronograph finger

Checking:

After correctly adjusting the position of minute recording jumper (refer to Adjust II-1), rotate the chronograph finger forward in a stopped condition, checking the degree with which the chronograph finger contacts the intermediate minute recording wheel.

- (1) The amount of such contact should be more than $\frac{1}{4}$ but less than $\frac{1}{2}$ the size of the flat end of the chronograph finger. (Fig. 21-A).
- (2) The chronograph finger should not touch other teeth on both sides of the tooth contacting the intermediate chronograph wheel.

Adjusting:

First straighten out the chronograph finger spring (the oblique lined stem in Fig. 22); then bend the basic portion (encircled) to effect desirable contact.

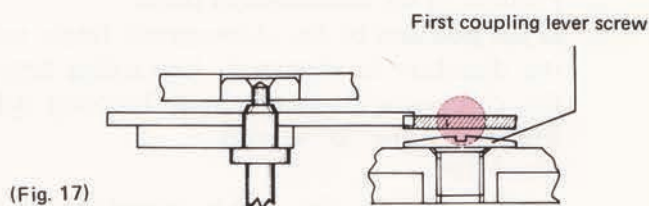

(Fig. 17)



(Fig. 18)

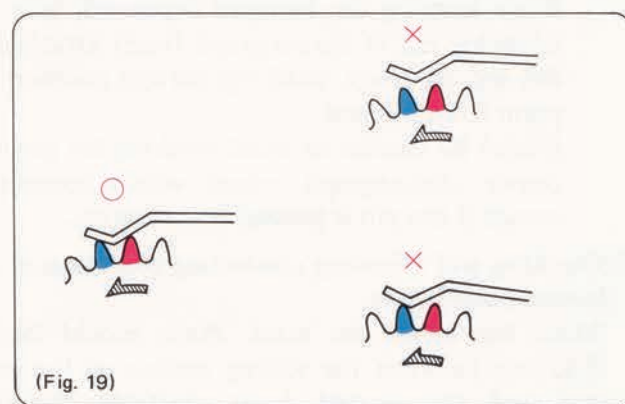

(Fig. 19)

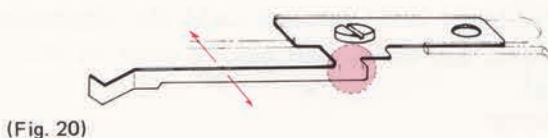

(Fig. 20)

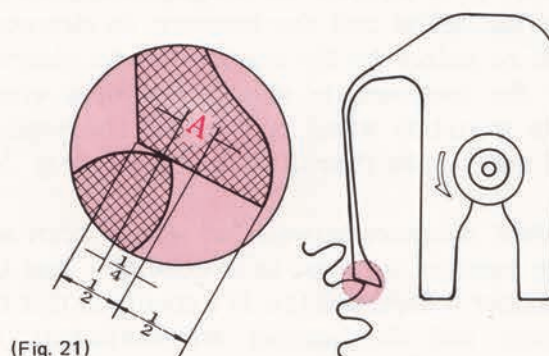

(Fig. 21)

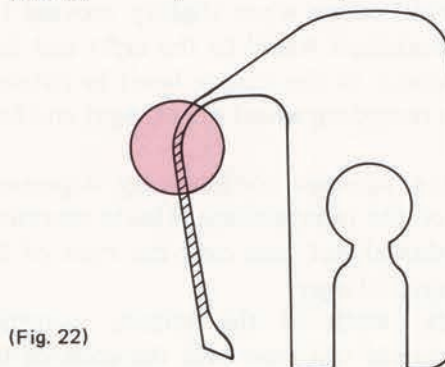

(Fig. 22)

6139A Checking and Adjusting the Chronograph Mechanism-3

2. Position of the chronograph finger

If the position of the chronograph finger rotating direction is abnormal, forwarding time of the chronograph minute hand becomes defective around the "0" second.

Checking:

After resetting the hands, point C of the chronograph finger must be straight on line between points A and B of the position setting hole. (Fig. 23)

Adjusting:

While keeping the hammer depressed, turn the adjusting pin of chronograph finger attached to the second heart, until the correct position for point C is obtained.

(Note) Be careful to avoid breaking the pivot of center chronograph wheel which sometimes occurs if the pin is pressed too strongly.

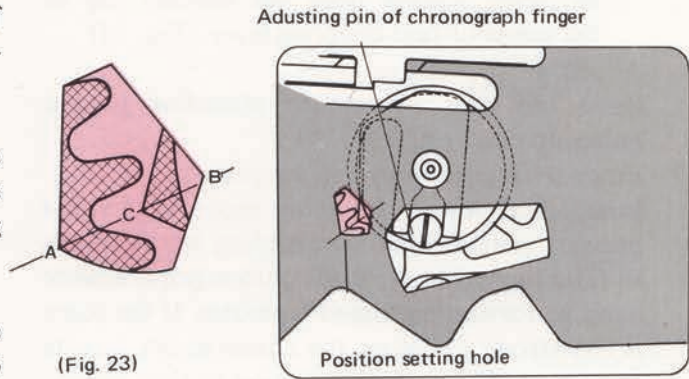

(Fig. 23)

IV. Checking and adjusting contacting condition of the hammer and hearts

When the hands are reset, there should be no clearance between the setting surface of the hammer and the second heart. Suitable clearance between setting surface of the hammer and the minute heart is 0.02mm. Should the clearance be excessive, the hands will not be reset to the "0" second.

Checking:

Actually, it is difficult to observe clearances between the hearts and the hammer, so clearances should be judged by the degree of shake observed when the intermediate minute recording wheel, minute recording wheel, and center chronograph wheel are reset to their original position. (Fig. 24)

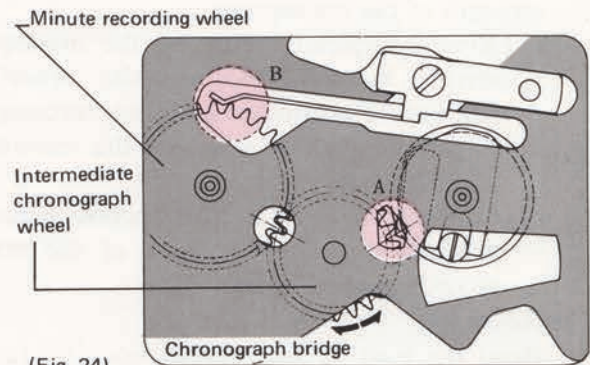

(Fig. 24)

1. Adjust clearance between the second heart and the hammer to zero. In a condition that the hammer is depressed (i.e. in a condition that the hearts and the hammer are contacted), no shakes should occur when slightly moving the center chronograph wheel to the right and left.
2. Check clearance of the minute heart by rotating the minute recording wheel to the right and left. (Table 1)
 - A. Keep the hammer continuously depressed. Teeth of the intermediate minute recording wheel should not pass over the crest of the chronograph finger.
 - B. Similarly, teeth of the minute recording wheel should not pass over the crest of the minute recording jumper.

	Intermediate minute recording wheel: A		Minute recording wheel: B	
Free condition				
When turning A to the right				
Adjustment	—	Polish second setting surface of the hammer	—	Polish second setting surface of the hammer

Table 1

6139A Checking and Adjusting the Chronograph Mechanism-4

Adjusting:

When shakes exist in the second heart:

Polish setting surface of the hammer contacting the minute heart.

When shake of the minute heart is excessive (when passing over the crest):

Polish setting surface of the hammer contacting the second heart.

(Note) When polishing the hammer, slightly file the point parallel to the setting surface, finishing to a mirrored surface. (Fig. 25)

V. Adjusting pressing strength of the second button (fly-back button)

Checking:

After installing the movement and the buttons on the case, check pressing strength of the second button.

Adjust pressing strength to the same as that of the first button. When the pressing strength is too strong, it will damage the chronograph mechanism.

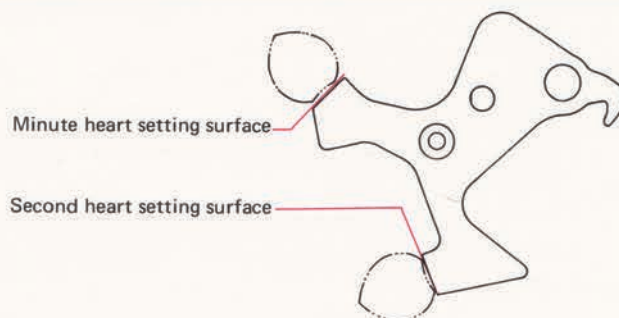

(Fig. 25)

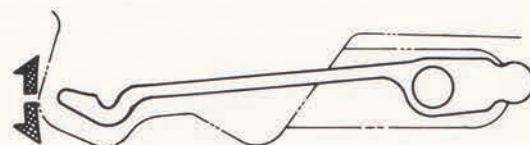

(Fig. 26)

Adjusting:

Bend tip of the hammer click by holding the pit portion. Do this carefully; the parts are apt to be damaged when it is bent too much.

Repairing the Chronograph Mechanism

I. Repairing Method

1. Center chronograph wheel—Damage due to:

- (1) Broken clutch spring
- (2) Strength of clutch spring too weak
- ✓ In these cases, the chronograph second hand either fails to move or moves irregularly.
- (3) Broken chronograph finger

Broken chronograph finger does not advance the chronograph minute hand.

If (1), (2) or (3) occur, replace the center chronograph wheel, referring to Checking and Adjusting the Coupling Levers mentioned in item I, Adjusting the Chronograph Finger mentioned in III, and Checking and Adjusting the Contacting Condition of the Hammer and the Hearts mentioned in IV of Chronograph Adjustment.

2. Loose chronograph second hand

If the chronograph second wheel does not reset to the "0" position when depressing the button, confirm the following point.

Check if the second hand moves when the second button is pressed. If it moves, the cause is due to loose contact of the second hand and center chronograph wheel axle. To correct this, reinsert the second hand to the extent that does not cause second hand catching.

3. Poor revolving efficiency of the fourth wheel

If the gear-train is not functioning well in a stopped condition, repair the watch after confirming the following points:

- (1) Check for correct shakes
- (2) Check for friction between each wheel
- (3) Check for correct revolving condition of the fourth wheel

As to confirming item (3), first install the chronograph bridge in a condition that the coupling levers are secured to the barrel and train wheel bridge. Next, as shown in Fig. 27, set the fourth wheel in a starting condition with the bosom side of the barrel and train wheel bridge built in the chronograph bridge upward. Next, after confirming clearance between the fourth wheel and clutch ring in a stopped condition, turn the fourth wheel and pinion with a soft brush to check whether or not it turns smoothly. If revolution is defective, clean and lubricate it (refer to Fig. 11) and reconfirm operation.

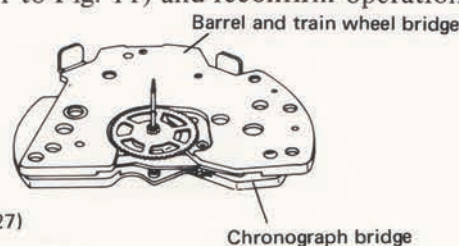

(Fig. 27)

Checking, Repairing and Adjusting Methods for Slipping of Chronograph Second Hand at the Fly-Back Position of Cal. 6138A and 6139A

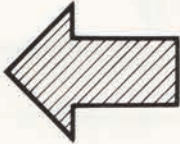

Checking, repairing, and adjusting methods of watch stopping at 58 second position of Cal. 6139 have been explained in detail in 6139A-14. On these pages, only slipping of chronograph second hand at the fly-back position is described.

When you are requested to repair slipping of the fly-back position, please refer to the following procedures.

Explanations in these pages can be utilized in common to both 6138A and 6139A.

- **Check Points Before Starting Repair**

- **When Chronograph Second Hand does not Return to "0" Position**

- **When Both Chronograph Second Hand and Minute Hand do not Correctly Return**

- **Overall Check Points after Repair**

Checking, Repairing and Adjusting Methods for Slipping of Chronograph Second Hand at the Fly-Back Position of Cal. 6138A and 6139A

If the chronograph second hand does not return to the "0" position when pushing the fly-back button (2nd button), confirm that the condition is Case 1 or Case 2, before repairing.

1 When the Chronograph Second Hand Does Not Return to "0" Position

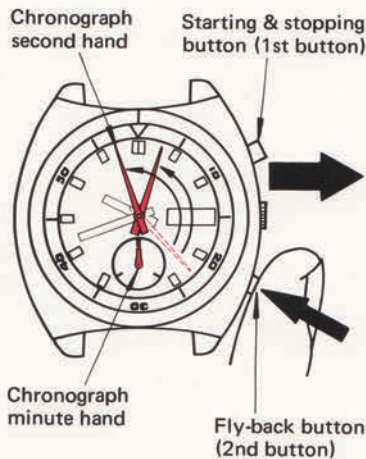

2 When both Chronograph Second Hand and Minute Hand Do Not Correctly Return

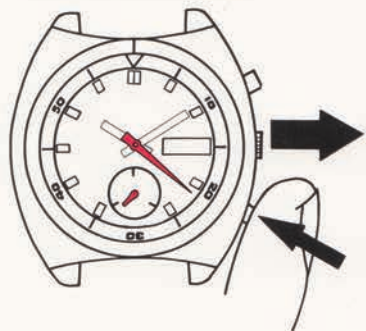

Hold the tip of the chronograph second hand with a pair of tweezers and move it slightly to the left and right while keeping the fly-back button completely depressed.

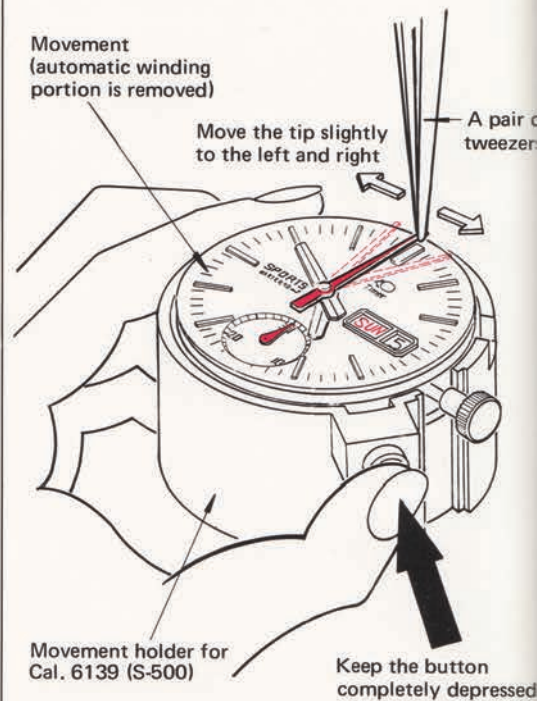

Remove the automatic winding section and check the position of a fly-back lever pin.

Note: The diagram show normal condition.

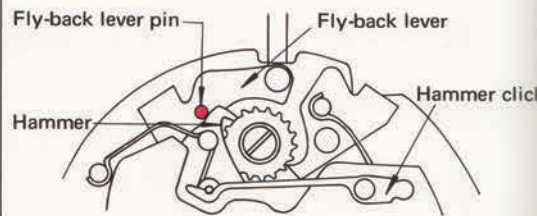

Overall Check Points After Repair

1. Pushing strength of the hammer button

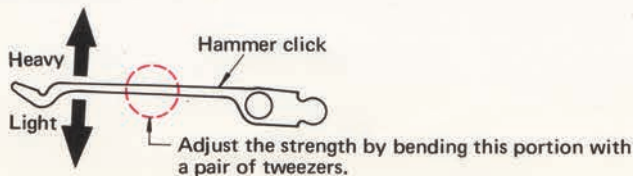

Recommended pushing strength of the fly-back button is the same as that of the starting and stopping button. If the strength is too heavy, the second hand is returned so quickly that the fly-back position may slip.



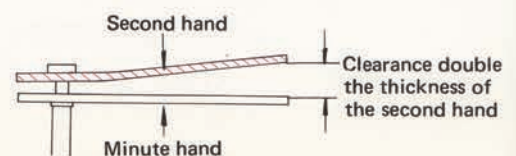

2. Clearance between second hand and minute hand

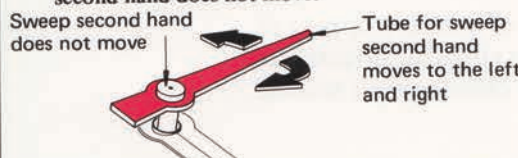
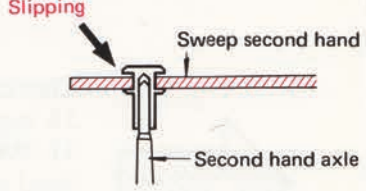
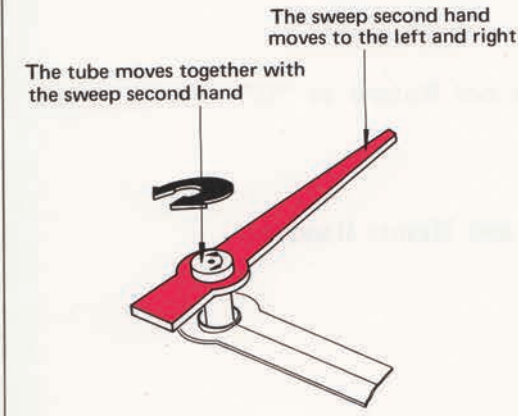
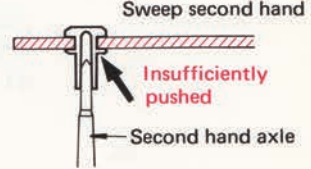
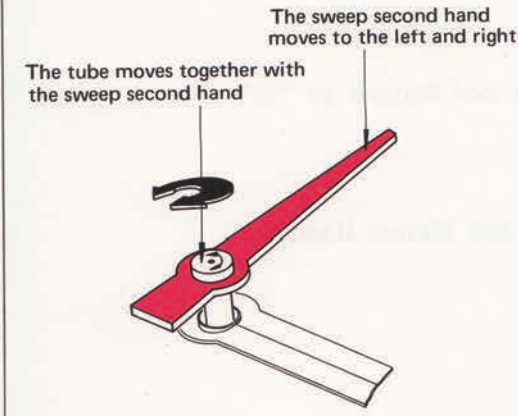
Create clearance double the thickness of the second hand between the second hand and the minute hand. After completely pushing in the second hand, adjust the clearance by bending the second hand upward.

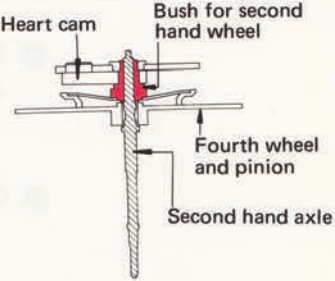

Check Points	Repairing and Adjusting Methods
<p>1. When only the sweep second hand moves while the tube for sweep second hand does not move.</p>  <p>Sweep second hand does not move</p> <p>Tube for sweep second hand moves to the left and right</p>	<p>This is caused by a slip between the sweep second hand and the tube for sweep second hand as shown in the diagram on the right.</p>  <p>Slipping</p> <p>Sweep second hand</p> <p>Second hand axle</p> <p>In this case, replace it with a new chronograph second hand.</p>
<p>2. When the sweep second hand and the tube for sweep second hand move together</p>  <p>The sweep second hand moves to the left and right</p> <p>The tube moves together with the sweep second hand</p>	<p>*(a) Insufficient installation of the second hand may cause this malfunction. First, completely push the second hand, and then recheck the fly-back position of second hand.</p>  <p>Sweep second hand</p> <p>Insufficiently pushed</p> <p>Second hand axle</p> <p>If this method is not effective, make a check (b).</p>
<p>The sweep second hand moves to the left and right</p>  <p>The tube moves together with the sweep second hand</p>	<p>(b) Detach the second hand and check the tube for sweep second hand</p> <p>* If the tube hole is enlarged too much or split as shown in the diagram on the right, replace it with a new sweep second hand.</p>  <p>Split tube</p> <p>(c) If the above-mentioned methods (a) and (b) are not effective, it may be caused by a slip between the bush for second hand wheel of the center chronograph wheel (in red color) and the second hand axle (oblique lines portion).</p>  <p>Heart cam</p> <p>Bush for second hand wheel</p> <p>Fourth wheel and pinion</p> <p>Second hand axle</p> <p>In this case, replace it with a new center chronograph wheel. At the same time, adjust the chronograph finger.</p> <p>Note: For details, refer to 6139A-9</p>

<p>1. When the fly-back lever pin is hidden under the hammer</p>  <p>Pin hidden</p>	<p>Move the pin to the correct position by moving the fly-back lever in the arrow direction.</p>
<p>2. When the fly-back lever pin comes off</p>  <p>Pin comes off</p> <p>Axle</p>	<p>Replace it with a new fly-back lever. (Before replacing, remove the barrel and train wheel bridge, and pull out the axle.)</p>

(Reference) Installation Method of Chronograph Second, Minute, and Hour Hands

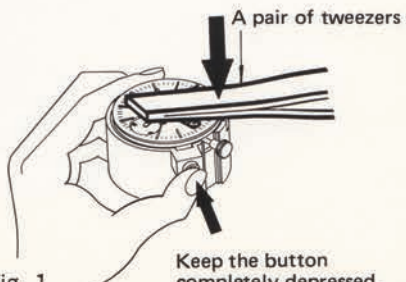
<ol style="list-style-type: none"> 1. After removing the automatic winding section, set the movement on the movement holder (S-500) for Cal. 6139. 2. After setting the second hand (or chronograph minute and hour hands) at the "0" position, push it in lightly while keeping the fly-back button completely depressed. (Fig. 1) 3. After confirming the fly-back position of the second hand, completely push in the second hand. <p>Note: Since the tip of the center chronograph wheel is shaped as shown in Fig.2, the second hand will be loosened when it is moved to the right and left after completely setting it.</p>  <p>Fig. 2</p>	 <p>A pair of tweezers</p> <p>Keep the button completely depressed.</p> <p>Fig. 1</p>
---	---

6139A CHECKING ON WATCH STOPPING, AND REPAIRING AND ADJUSTING PROCEDURES

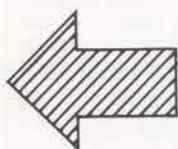

Regarding repairing and adjusting of Cal. 6139A, we have already mentioned them in the SEIKO TECHNICAL GUIDE. However, on these pages, items to be checked on watch stopping, and repairing and adjusting for each item, are compactly arranged to facilitate further comprehension.

EXPLANATIONS REGARDING WATCH STOPPING AT 58 SECOND POSITION

- **A watch stopping at 58 second position is not malfunctional.**

When the mainspring winding is insufficient the second hand always stops at the 58 second position.

But this is not a malfunction.

- **The reason why a watch stops at 58 second position:**

In the 6139A, when the second hand moves from 58 to 60 second, the mechanism is devised so that the chronograph minute hand moves one graduation. At the 58 second position where the chronograph minute hand moves, a larger mainspring force is required.

Consequently, when the mainspring is nearly unwound, 6139A always stops at the 58 second position.

- **A watch in the following condition is defective.**

When the second hand stops at the 58 second position in spite of a fully wound mainspring, the watch is defective. Repair and adjust it according to the following procedures.

1. **Items to be checked before beginning repair works.**
 - * Checking the number of remaining windings of the mainspring
2. **When the balance stops at the 58 second position.**
3. **When the second hand stops at the 58 second position and the balance is still moving.**

6139A CHECKING ON WATCH STOPPING, AND REPAIRING AND ADJUSTING PROCEDURES

(Example of stopping at 58 second position)

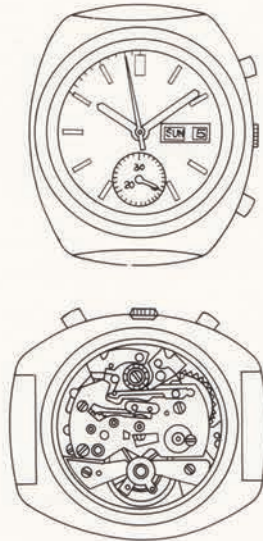

1 Confirm the Following Items Before Beginning Repair Work

- A. Check *the number of remaining windings of the mainspring of the watch, of which the second hand stops at the 58 second position as shown in the above diagram.
- B. In this case, when the number of remaining windings of the mainspring is.....
 - More than 1 - 1.5 windings.....Adopt Procedure2
 - Under 1 winding..... Adopt Procedure3

*Checking the number of remaining windings of the mainspring

1. Remove the automatic winding section (oscillating weight section).
2. Firmly hold the ratchet wheel screw with a driver and release the click by using a pair of tweezers.
3. In this condition, gradually turn the ratchet wheel screw counterclockwise until the mainspring power is exhausted (releasing the mainspring).
4. This revolving number of the ratchet wheel screw corresponds with the number of remaining windings of the mainspring.

(Note)

It is convenient to count the number of remaining windings of the mainspring by confirming the direction of the groove of the ratchet wheel screw.

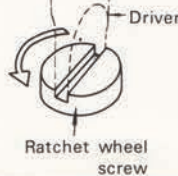

When the number of remaining windings of the mainspring exceeds 1 - 1.5 windings

2 When the Balance stops at the 58 second Position

In this case, inspect the watch according to CHECKING PROCEDURES 4 through 6 after removing the case back and the automatic winding section (oscillating weight section).

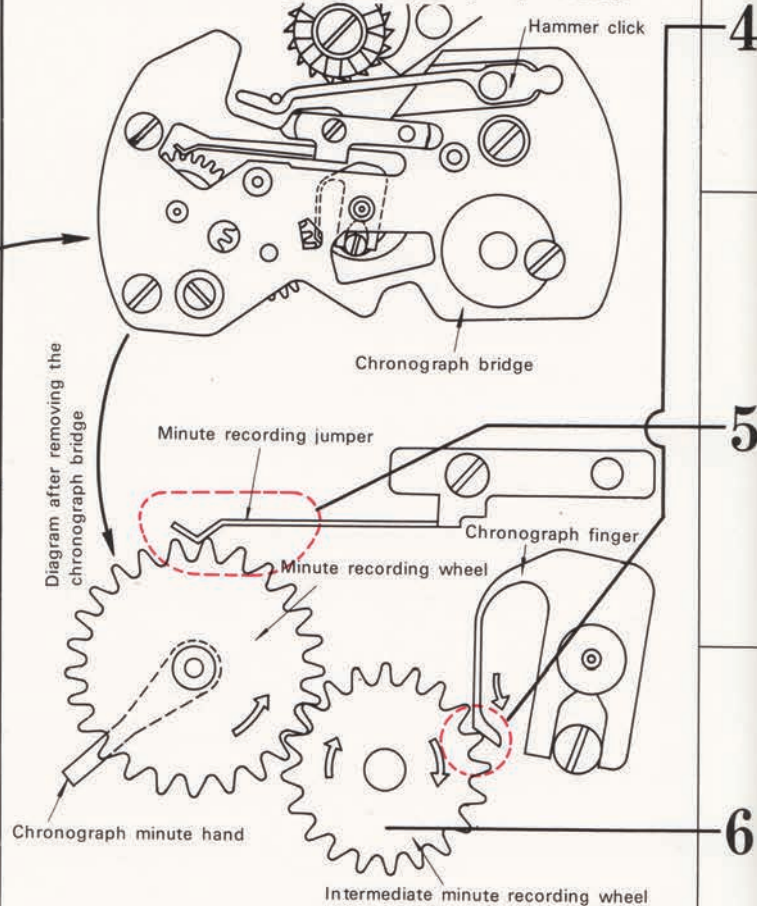

When the number of remaining windings of the mainspring is under 1 winding

3 When the Second Hand stops at the 58 second Position and the Balance is Still Moving

In this case, inspect the watch according to CHECKING PROCEDURE 7.

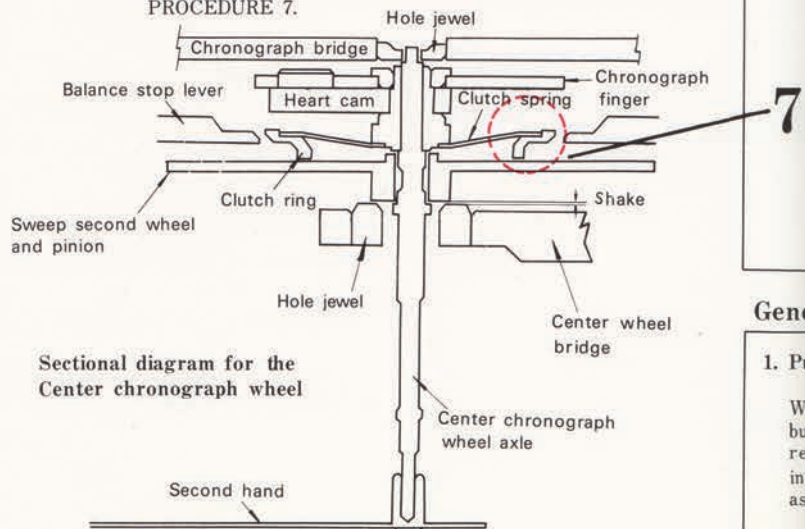

Checking procedure

4

5

6

7

General

1. Pu

Wh
but
res
ing
as

Checking details

Check the condition when the chronograph finger contacts the intermediate minute recording wheel (when the minute forwarding is ready to start).

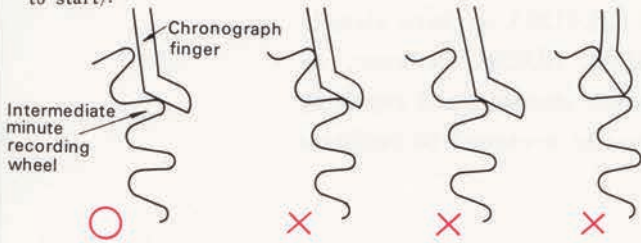

Repairing and checking methods

In case of **×** Adjust the amount which the chronograph finger contacts with the wheel by bending this portion in the \rightarrow or \leftarrow direction, holding it with a pair of tweezers.

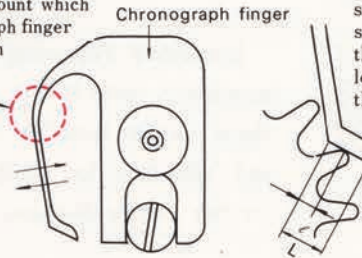

The amount of such contact (ℓ) should be more than $1/4$ but less than $1/2$ the size of L .

Check whether or not teeth of the minute recording wheel are forwarded by winding the ratchet wheel only half a revolution after completely releasing the mainspring.

At 58 - 59 second	At 60 second	Judgment
		○
	(Stopping)	×

In case of **×**, create a forwarding condition by winding the ratchet wheel only half a revolution after completely releasing the mainspring. To satisfy both following ① and ②, adjust strength of the minute recording jumper spring.

① Minute forwarding is correctly performed between 58 and 60 second position.
② After performing minute forwarding, chronograph finger always must be geared correctly into the wheel.

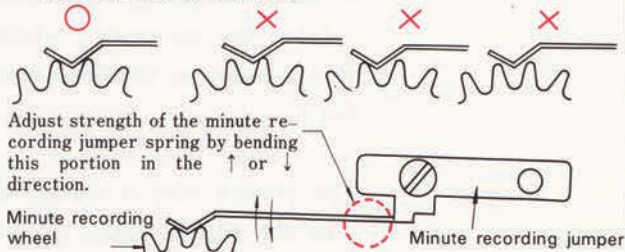

Adjust strength of the minute recording jumper spring by bending this portion in the \uparrow or \downarrow direction.

Minute recording wheel

(Note) When the minute is not forwarded in spite of weakening the strength of minute recording jumper, first check and correct the watch according to Procedure 6; then adjust strength of the minute recording jumper.

Remove the chronograph bridge and check on revolving condition of the intermediate minute recording wheel.

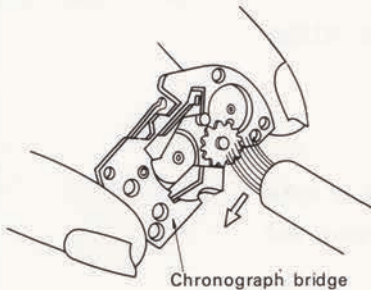

Lightly turn the intermediate minute recording wheel with a soft small brush.

Turns lightly ○
Turns heavily ×

When the intermediate minute recording wheel turns heavily (**×**), wash the chronograph bridge with an ultrasonic cleaner.

(Note) Never lubricate the intermediate minute recording wheel.

(When the second hand stops at the 58 second position and the balance is still moving, the cause is due to slipping of the clutch ring.)

(Note) If the shake of the center chronograph wheel is excessive, the second hand moves intermittently in spite of stopping condition. Adjust the shake properly (the shake is proper when it is almost the same as ordinary wheel's).

Remove the center chronograph wheel and sufficiently wash it; then lubricate between the fourth wheel and the center chronograph wheel axle with Moebius Synt-A-Lube. Confirm the moving condition of the clutch. When the clutch is loosened, replace the center chronograph wheel with a new one. In this case, properly adjust shake of the new center chronograph wheel.

Chronograph bridge

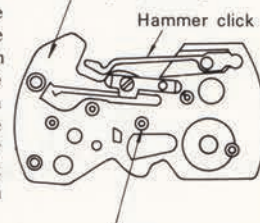

Adjust the shake by raising or lowering this hole jewel. (Adjust it on a staking tool or a riveting-stake).

General Checking Procedures After Repairing

Adjusting strength of the hammer button

When pushing strength of the hammer button is too heavy, the second hand is reset too fast, causing a defective resetting position. Consequently adjust it lightly as far as possible.

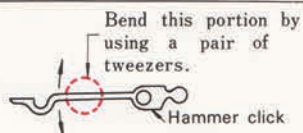

(When adding weight.... \uparrow direction)
(When reducing weight.... \downarrow direction)

2. Clearance between hands

When the clearance between the second hand and the minute hand is too narrow, sometimes the second hand scratches the minute hand when resetting. Always check the clearance between the hands.

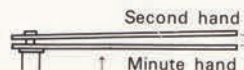

Create a clearance of approximately double the thickness of the second hand

(Note) When installing the second hand, use the movement holder (S-500) for 6139A.

6139A After-Sales Service-Trouble-Shooting

The chronograph mechanism is very precisely constructed. When repair is requested, it is important to listen to the customer describe the watch condition. Further, it proves especially valuable in ensuring correct repair to classify the

cause according to the following table, based on the description described by the customer. Listing malfunction of the chronograph mechanism, their causes, and corrective actions. This table can be used effectively.

Mechanisms	Phenomena	Causes	
Starting stopping mechanism	First and/or second buttons do not move	<ul style="list-style-type: none"> Button gasket worn out Dust adhered around button axle Lack of silicon grease 	
	Mechanism does not start even when depressing button	<ul style="list-style-type: none"> Deeper than necessary interlocking of chronograph finger Refer to C Damaged center chronograph wheel Refer to C Unsmooth operation of first and second coupling levers Hands catching 	
	Defective forwarding time of chronograph minute hand	<ul style="list-style-type: none"> Defective position of minute forwarding Refer to C Loosened chronograph second hand Refer to C 	
	Chronograph minute hand only moves in middle of graduation	<ul style="list-style-type: none"> Shallow interlocking of chronograph finger Refer to C Weak minute recording jumper Refer to C Detached minute recording jumper Refer to C Malfunction of intermediate minute recording wheel turning Chronograph minute hand catching 	
	Chronograph minute hand stops in forwarding condition	<ul style="list-style-type: none"> Deep interlocking of chronograph fingers Refer to C Strong minute recording jumper Refer to C Detached minute recording jumper Refer to C Insufficient amplitude Malfunction of intermediate minute recording wheel turning 	
	Chronograph minute hand not being forwarded	<ul style="list-style-type: none"> Damaged center chronograph wheel Refer to C Shallow interlocking of chronograph wheel Refer to C 	
	Chronograph minute hand forwarded simultaneously with starting	<ul style="list-style-type: none"> Defective chronograph finger position Refer to C 	
	Hands do not stop even when depressing first button to stop position	<ul style="list-style-type: none"> Damaged center chronograph wheel Refer to C Clutch spring raises only slightly Refer to C 	
	Resetting mechanism	Defective pressing condition of buttons	<ul style="list-style-type: none"> Abrased button gasket Lack of silicon grease Weak hammer click Refer to C Lack of oil on fly-back lever pin
		Second hand does not reset to the "0" position	<ul style="list-style-type: none"> Deep interlocking of chronograph finger Refer to C Loosened chronograph second hand Refer to C Abrased hammer Refer to C
Chronograph minute hand does not reset to the "0" position		<ul style="list-style-type: none"> Deep interlocking of chronograph finger Refer to C Weak minute recording jumper Refer to C Detached minute recording jumper Refer to C Excessive shakes of minute heart and hammer Refer to C 	
Hands do not reset even when depressing the second button		<ul style="list-style-type: none"> Damaged fly-back lever pin 	
Defective durability	No durability in starting condition	<ul style="list-style-type: none"> Deep interlocking of chronograph finger Refer to C Damaged center chronograph wheel Refer to C Strong minute recording jumper Refer to C Insufficient amplitude 	
	No durability in stopping condition	<ul style="list-style-type: none"> Friction of fourth wheel Defective rotating condition of fourth wheel Refer to C Insufficient amplitude 	

sed on details
actions in the
corrective actions,

Corrective action

Chronograph Adjusting III-1
to Chronograph Repairing I

Chronograph Adjusting III-2
to Chronograph Repairing I

Chronograph Adjusting III-1
Chronograph Adjusting II-3
Chronograph Adjusting II-2

Chronograph Adjusting III-1
Chronograph Adjusting II-3
Chronograph Adjusting II-2

to Chronograph Repairing I
Chronograph Adjusting III-1

Chronograph Adjusting III-2

to Chronograph Repairing I
Chronograph Adjusting I-1

to Chronograph Adjusting V

Chronograph Adjusting III-1
to Chronograph Repairing I
Chronograph Adjusting IV

Chronograph Adjusting III-1
Chronograph Adjusting II-3
Chronograph Adjusting II-2
Chronograph Adjusting VI

Chronograph Adjusting III-1
to Chronograph Repairing I
Chronograph Adjusting II-3

to Chronograph Repairing I